

- A. DIAMETER BEING CUT AT THE TIP'S ENDS
- B. THE DIAMETER BEING CUT AT THE TIP'S MIDPOINT
- C. THE TIP'S CUTTING EDGE.
- D. THE ENDS OF THE TIP.

SK.1

CONVEX SURFACE CUT WITH A STRAIGHT EDGE TIP

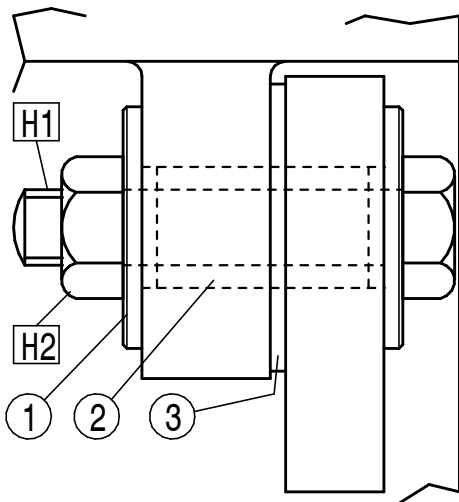

HARDWARE
 H1 M10 X 50 STEEL HEXAGON HEAD SCREW
 H2 M10 STEEL NUT
MODIFIED HINGE ASSEMBLY SK.2

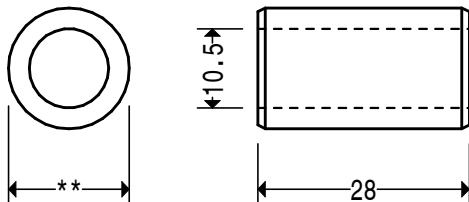

MATL. 20MM DIA. STEEL 230M07
 QTY. 2 OFF

** MAKE A CLOSE FIT IN THE HOLES IN THE LUGS

BUSH PART 2

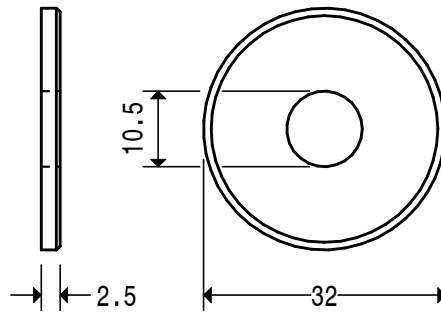

MATL. 32MM DIA. STEEL 230M07
 QTY. 4 OFF
WASHER PART 1

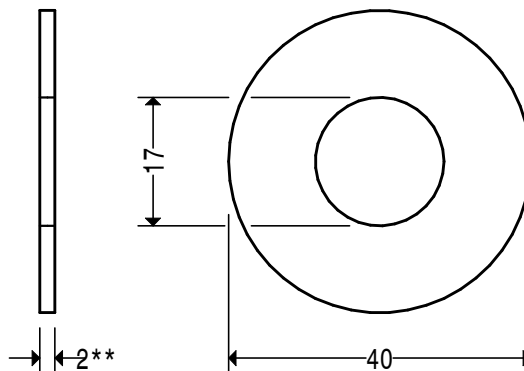

MATL. 40MM DIA. STEEL 230M07
 QTY. 2 OFF

** NOMINAL DIMENSION, MAKE TO FIT.

SPACER PART 3