

SHORT DRILL EXTENSION
GIVES MORE CLEARANCE

SK. 1

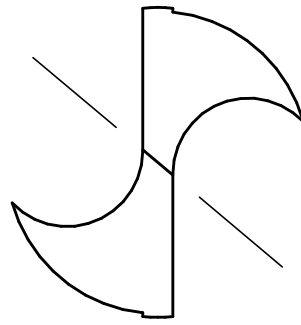

CORRECT CLEARANCE

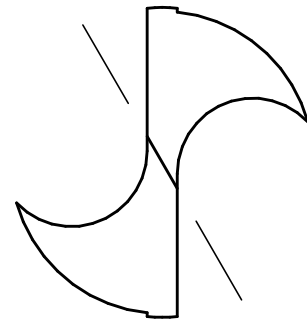

INCREASED CLEARANCE

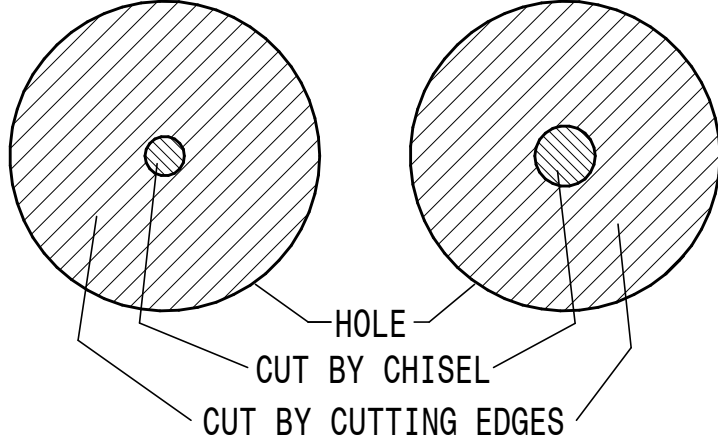

EFFECT OF DRILL CLEARANCE
ON CHISEL ANGLE

SK. 4

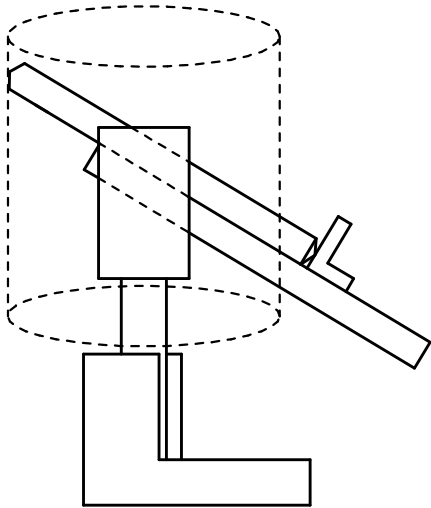

LARGE DRILL EXTENSION GIVES
LESS (FLATTER) CLEARANCE

SK. 2

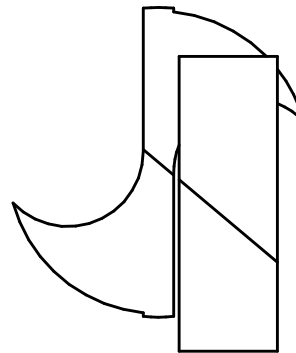

CHISEL ANGLE
GAUGE

SK. 5

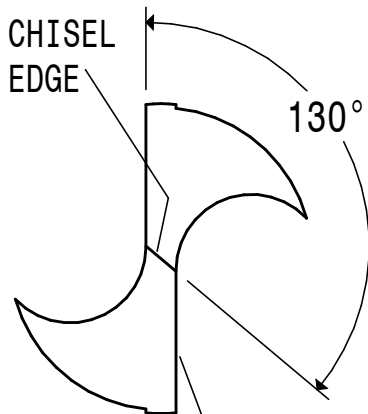

SK. 3

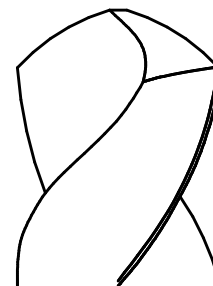

DOMED POINT
SK. 6