

HOLES A. 8.5 2 OFF B. 6.5 4 OFF

MATERIAL 40 X 3 STEEL 070M20, OR SHEET STEEL

NOTE. THE DIMENSIONS GIVEN SUIT A BLACK AND DECKER PROFESSIONAL GRINDER AND MUST BE CHECKED FOR ANY OTHER MAKE.

**SUPPORT 7**

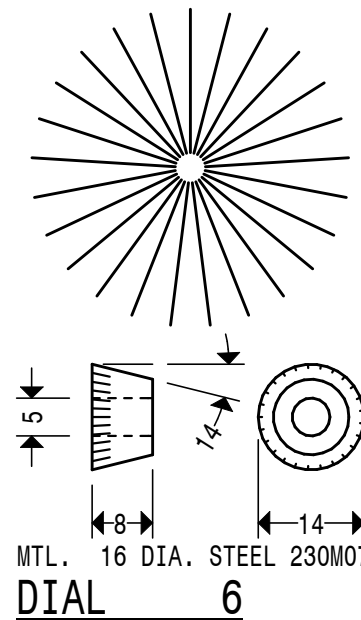

MTL. 16 DIA. STEEL 230M07

**DIAL 6**

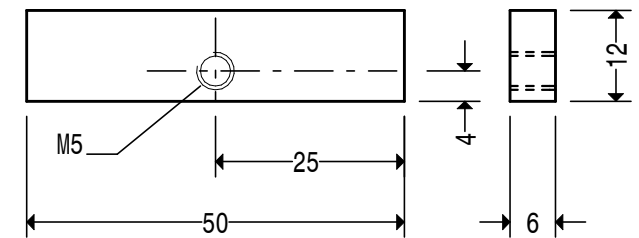

MATERIAL 12 X 6 STEEL 070M20

**NUT 8**

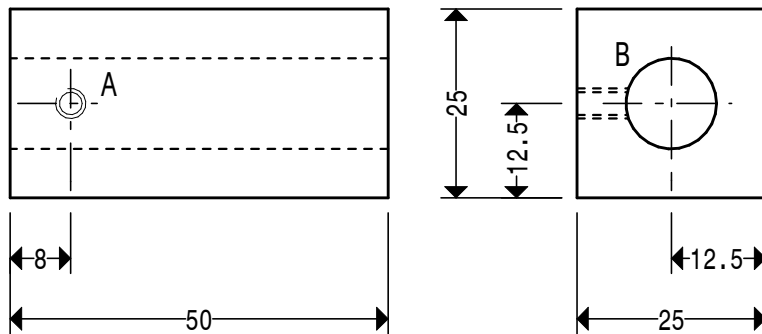

HOLES A. M4 B. TO SUIT CUTTER SHANK

MATERIAL. 25 SQ. STEEL 230M07 **CUTTER HOLDER 1**

**SHARPENING END MILLS**

11-09-2010

SharpEM3