

MAKING THE BOTTOM PLATE (C17) THICKER AND WITH A RECESS WILL ENABLE THE CROSS SLIDE TO BE MOVED NEARER THE HEAD'S COLUMNS

BOTTOM PLATE MODIFICATION SK. 1

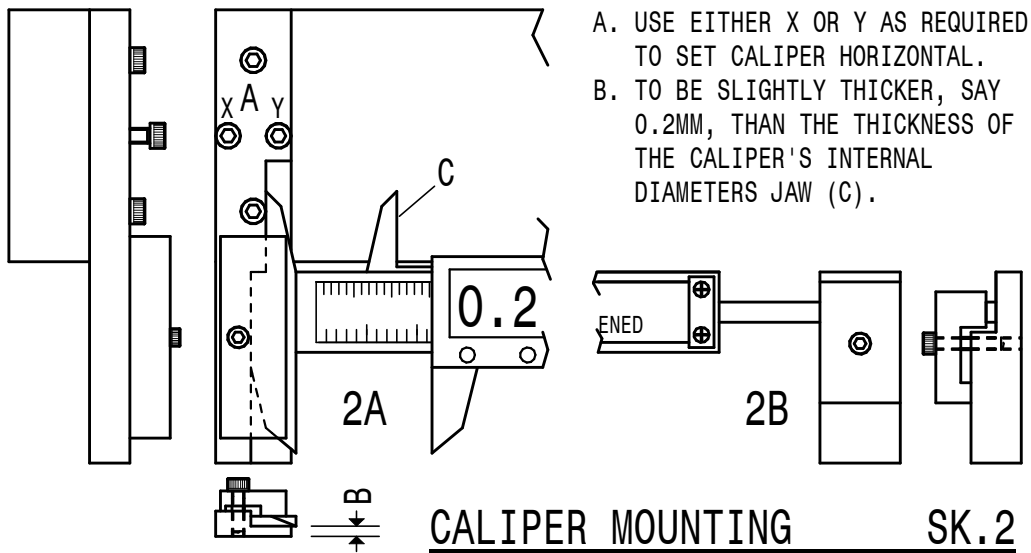

- A. USE EITHER X OR Y AS REQUIRED TO SET CALIPER HORIZONTAL.
- B. TO BE SLIGHTLY THICKER, SAY 0.2MM, THAN THE THICKNESS OF THE CALIPER'S INTERNAL DIAMETERS JAW (C).

CALIPER MOUNTING SK.2