

BODY.1

MATERIAL 50MM SQ STEEL 230M07 QTY 1 OFF

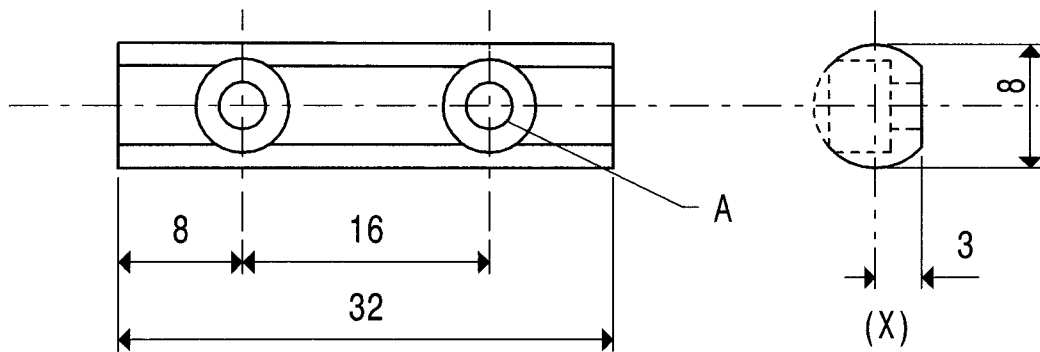

A. 3.1 DIA. CB 5.5 DIA. X 3.5 DEEP
 X. THIS IS A REFERENCE DIMENSION. INCREASE DEPTH OF FLAT UNTIL KEY IS A CLOSE FIT IN 7 WIDE SLOT IN BODY, (1). SECOND FLAT TO BE MADE AFTER ASSEMBLY TO THE BODY. SEE SK.1 (DRAWING 5)

MATL. 8mm DIA. STEEL 230M07
 QUANTITY. 2 OFF.

LOCATING KEY. 6

QUICK CHANGE LATHE TOOL POST.

