

S = HALF THE CHOSEN COLLET DIAMETER PLUS 1MM MINIMUM.

MATERIAL STEEL 230M07

L IS FOR MAKING TWO SETS OF JAWS AND SHOULD BE TWICE THE CHOSEN JAW LENGTH PLUS 5MM, SUGGESTED JAW LENGTH 25MM MINIMUM

PREPARING JAW BLANKS FOR MACHINING

SK1

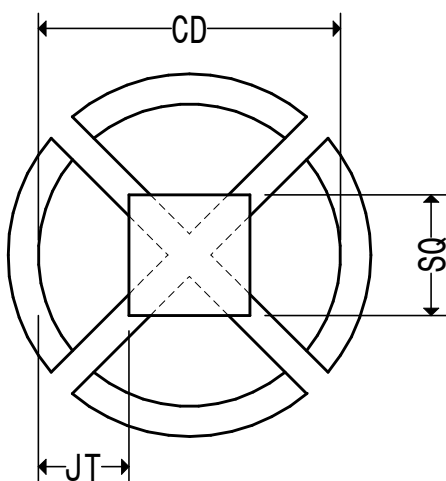

CD COLLET DIAMETER
 SQ SIZE OF MATERIAL
 TO BE HELD
 JT JAW THICKNESS

$$JT = \frac{CD - SQ}{2}$$

JAW THICKNESS SK2